

SY2515-RJ45 front-nut mount panel socket assembling instruction

1. Unscrew the cap

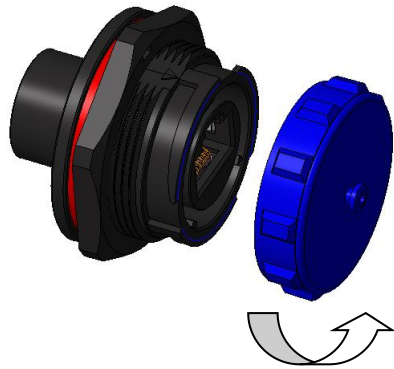
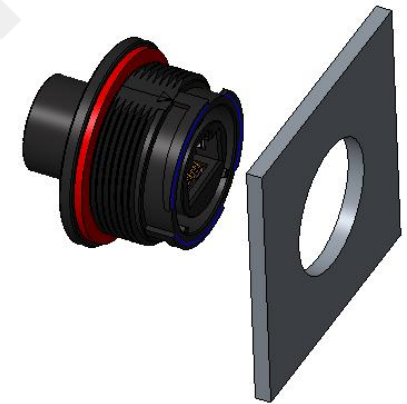

2. Unscrew the nut

3. Put the socket into the panel.
(max panel thickness:3mm)

4. Tighten the nut according to torque of 1-1.1N.m

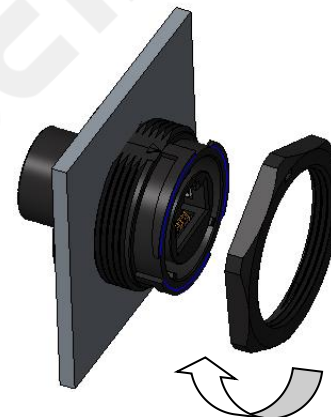

5. Tighten the cap and finish assembling.

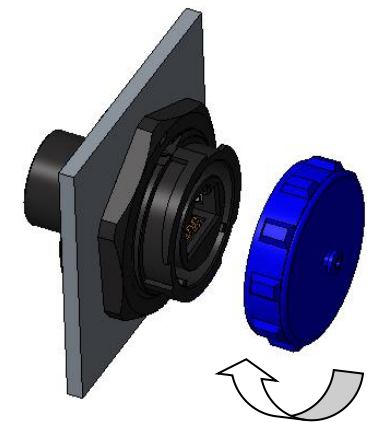

Panel cutout

