

## SP、SY Series 2-hole Flange Socket Solder Assembling Instruction

1、Strip the wire based on the recommended length below.

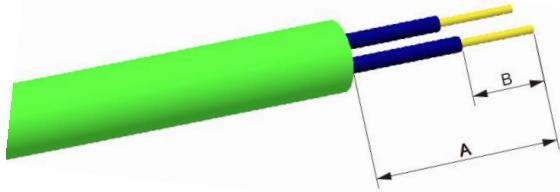

Series	A(mm)	B(mm)
SP21/SY21/SP25/SY25	12	6
SP29/SY29	12	6

2、Solder the wire and then wrap it with a heat-shrinkable tube.

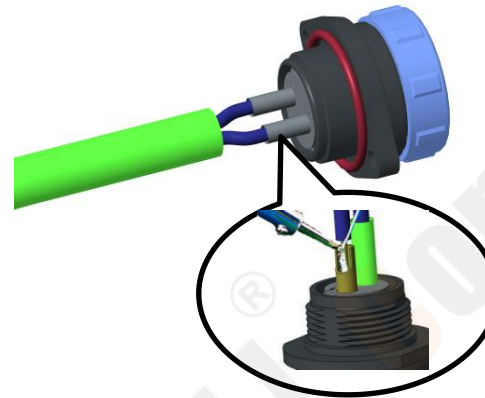

3、Drill the hole based on the suggested panel cutout size.

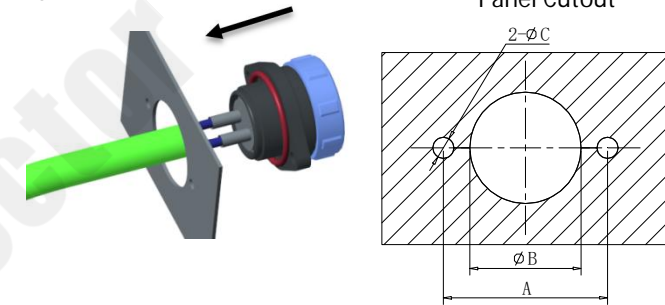

Series	A(mm)	B(mm)	C(mm)
SP21/SY21	31	21	4
SP25/SY25	40	25	5
SP29/SY29	45	28	5

4、Put the assembled cable into the panel.

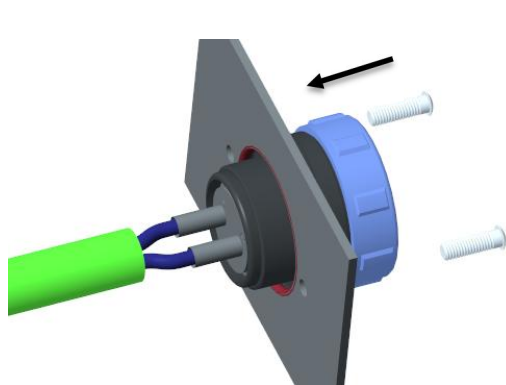

5、Install the screws and fix.

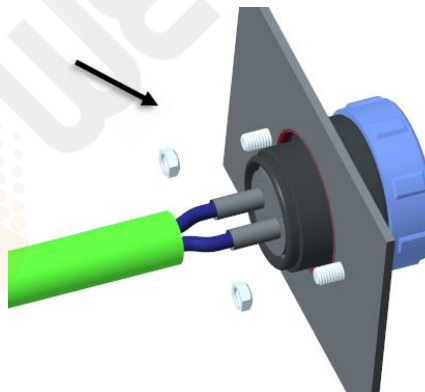

6、Screw locking torque: 0.1-0.15N.M

