

WA22J7TK1、WA22K7TK1 Assembling Instruction

1. Strip the cable. (mm)

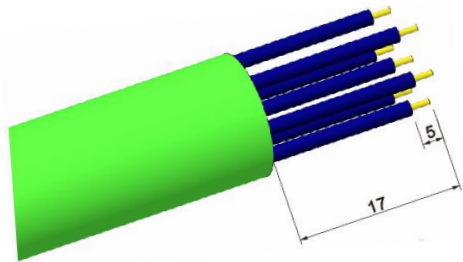

2. Put the cable through all parts.

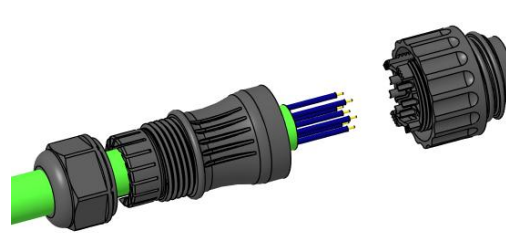

3. Tin solder to contact.

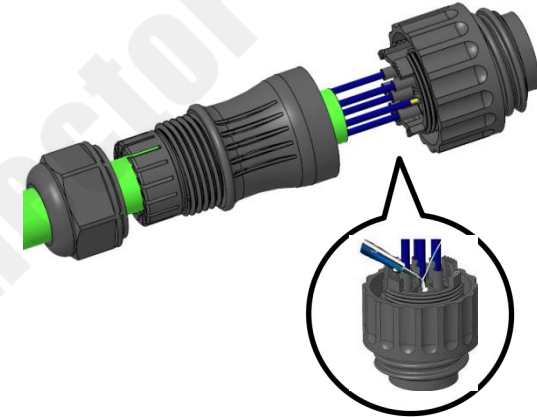

4. Tighten the backshell according to the torque.

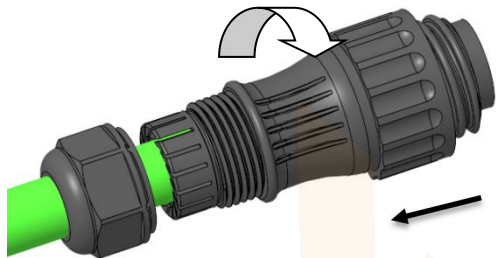

Standard Torque (N*m)

1.50-2.00

5. Tighten the compression nut according to the torque.

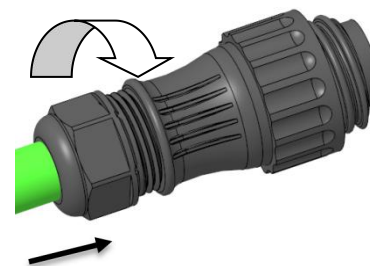

Standard Torque (N*m)

1.50-2.00

WA22J7TL1、WA22K7TL1 Assembling Instruction

1. Strip the cable. (mm)

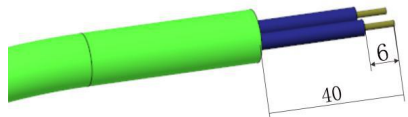

2. Put the cable through all parts.

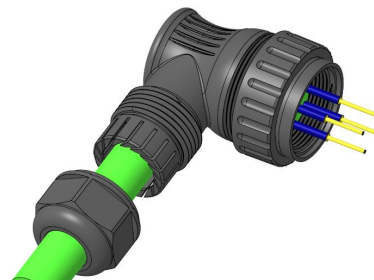

3. Tin solder to contact.

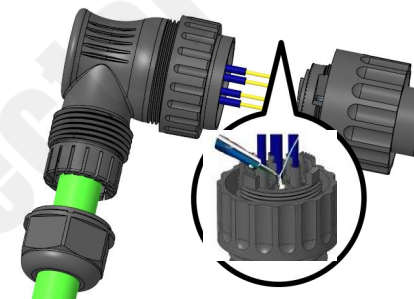

4. Tighten the backshell according to the torque.

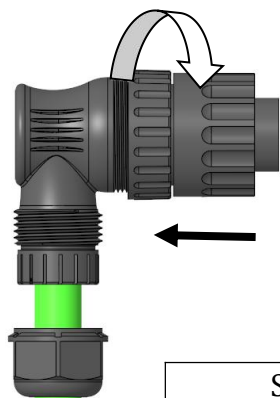

Standard Torque (N*m)
1.5-2.0

5. Tighten the compression nut according to the torque.

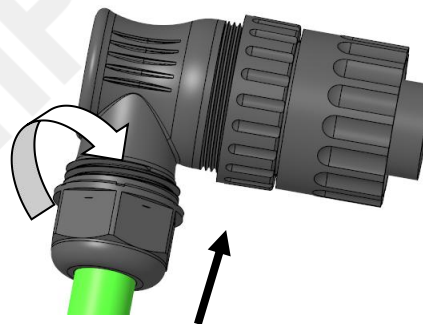

Standard Torque (N*m)
1.5-2.0

WA22J7TE1、WA22K7ZE1 Assembling Instruction

1. Strip the cable. (mm)

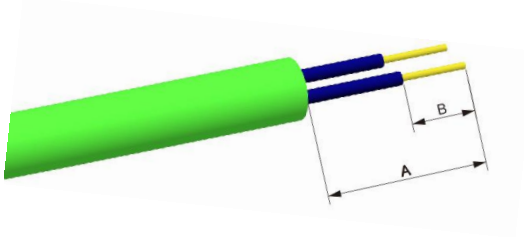

	A(mm)	B(mm)
WA22K4ZE2	21	6

2. Put the cable through all parts.

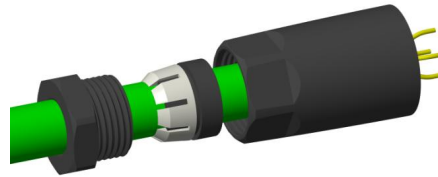

3. Tin solder to contact.

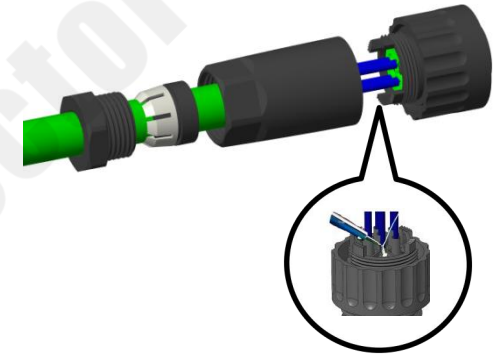

4. Tighten the backshell according to the torque.

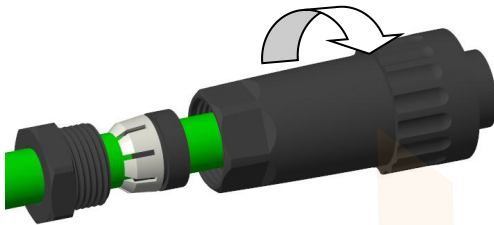

Standard Torque (N*m)
1.5-2.0

5. Tighten the compression nut according to the torque.

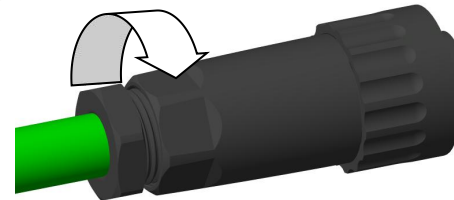

Standard Torque (N*m)
1.5-2.0

WA22K7Z1、WA22J7Z1 Assembling Instruction

1. Strip the cable. (mm)

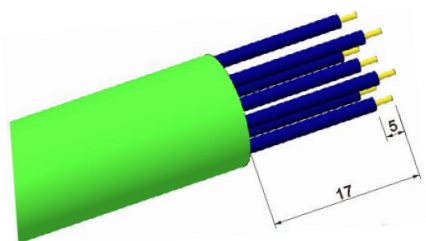

2. Put the cable through all parts.

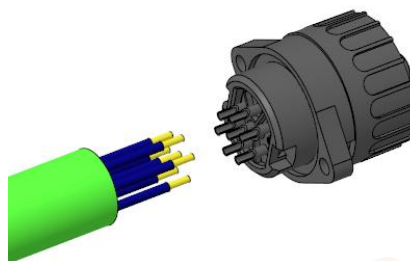

3. Tin solder to contact.

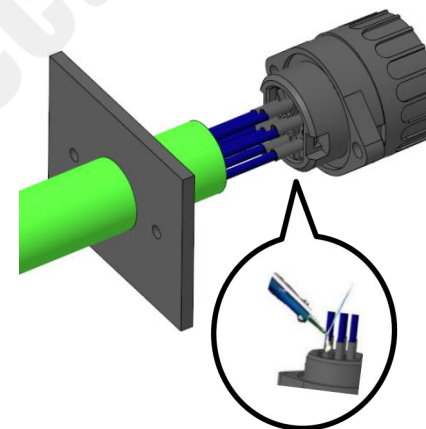

4. Tighten the screws to fix the socket.

